

Step 2: Add the peak detector (D2, R20, C7) to the output of the rectifier as shown below. choose appropriate values for R20 and C7 from the components available to you in the Lab-in-a-Box for this peak detector assuming that the lowest signal frequency is around 100Hz.

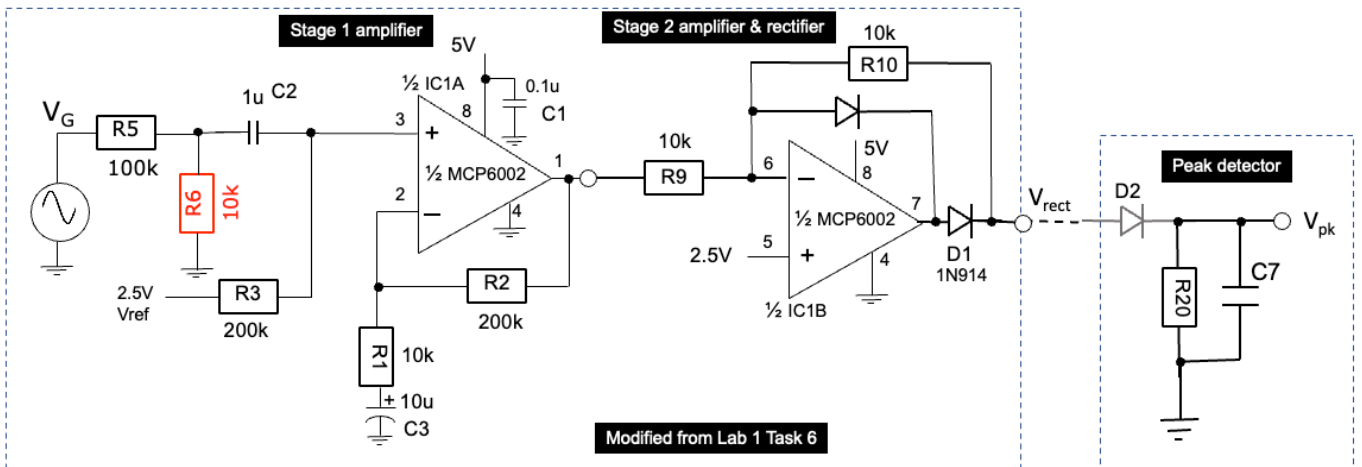

Step 3: Connect the input of Stage 1 amplifier to the microphone (instead of the signal generator). Choose a value for R9 such that the maximum voltage at V_{rect} is around 4V. Test this circuit by feeding sound to the microphone. *Hint: One easy way to do this is download a free tuning fork app to your phone and play a pure tone at say, 1kHz.*

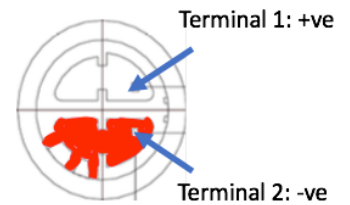

Bottom view

Note that the microphone has polarity. The -ve terminal can be identified as the one is connected to the CASE of the microphone as shown here. This should be connected to GND. You can download a copy of the specification for this microphone from the course webpage.

Verify that V_{pk} is as you expected.

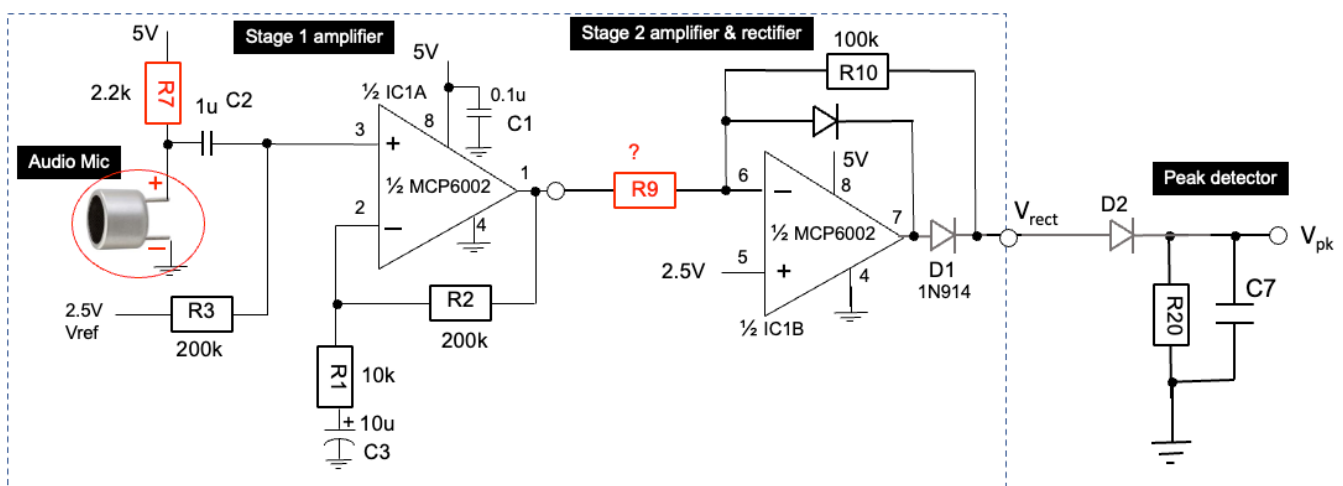

Task 2: Building an analogue voltage comparator & audio signal detector

Step 1: Use a **second** MCP6002 device (IC2) provided in the Lab-in-a-Box and build the voltage comparator circuit as shown below.

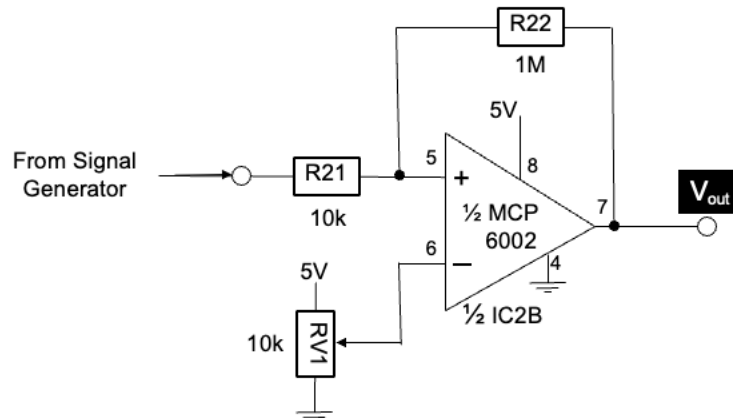

Set the signal generator to produce a sine wave at 1kHz with 1V amplitude and 1V DC offset. Adjust the variable resistor RV1 and observe the output V_{out} . What is the signal voltages at which the output changes states? Explain your observations and why the threshold voltages of the comparator changes depending on the output state of the comparator.

Increase the signal frequency and observe what happens. What are the rise and fall times of the output of the comparator? Does this agree with the MCP6002 data sheet?

Step 2: Replace the generated signal with the peak detected signal V_{pk} from Task 1 Step 3 as shown. Replace the variable resistor RV1 with a fixed voltage at around 3.75V using a voltage divider. (You will need RV1 for something else later.)

Connect the BLUE LED at the output as shown. Verify that BLUE LED indicates the presence or absence of sound picked up by the microphone. For example, the LED should flash when you clap your hands.

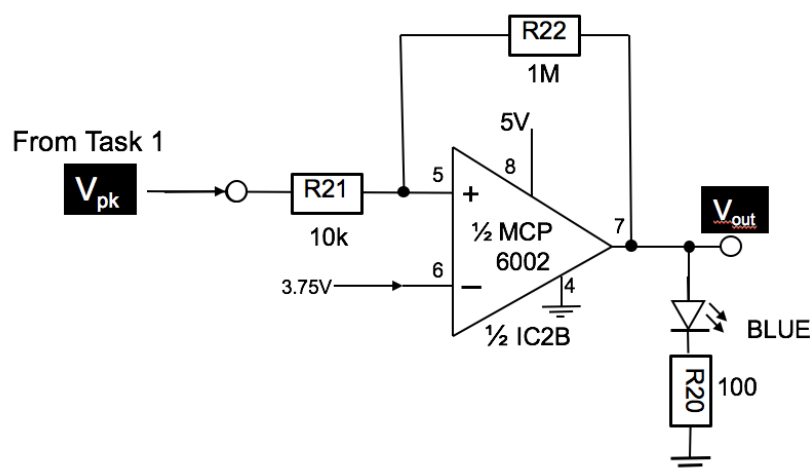

Task 3: Function Generator

Step 1: Construct the circuit shown below using the THIRD MCP6002 provided. R25 should be 100k for now. (You must leave the other two MCP6002 chips (IC1 and IC2) alone because you will need them later.)

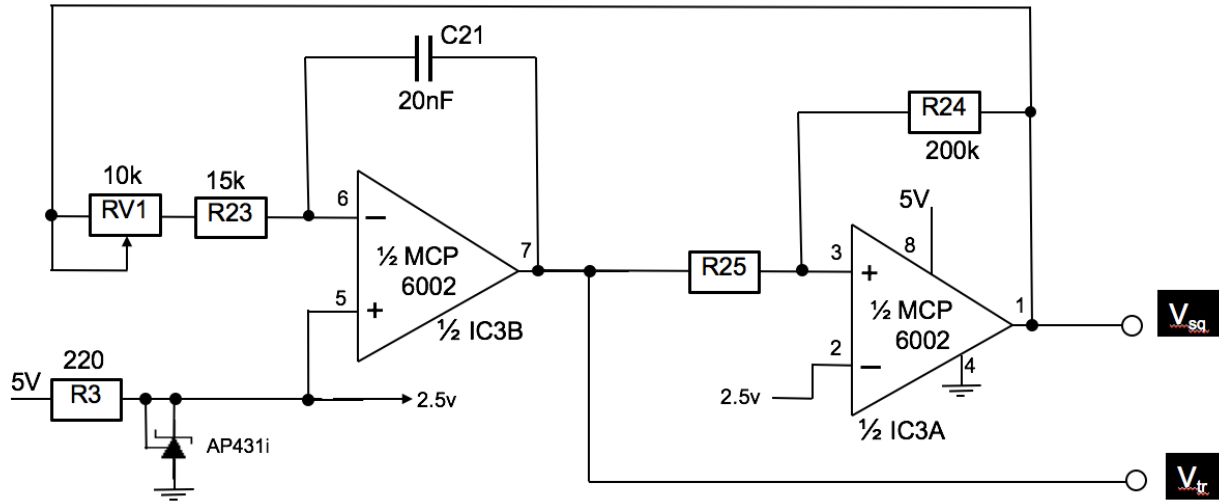

The first stage op-amp is used as an integrator.

Derive the maximum and minimum slope for the signal at pin 7 with RV1 set to 0Ω and to 10k Ω.

The second stage op-amp is used as a voltage comparator.

Derive its threshold voltages (i.e. the voltage at which the output switches state).

Hence, deduce the frequency range of the generated triangular and square signals when the loop is closed by connecting the output of the comparator (pin 1) to the input of the integrator.

Step 2: Modify R25 to 150kΩ. Explain the resulting triangular and square signals.

By the end of this task, you should be able answer the following two questions. What determines:
 1) the amplitude of the triangular signal? 2) the frequency of oscillation?

Task 4: Lowpass Active Filter – Salley-Key architecture

Shown below is a basic Salley-Key lowpass filter. Assuming that $R_{26} = R_{27} = 15\text{k}\Omega$, verify that the cut-off frequency of this lowpass filter is around 1kHz. Construct this circuit using the unused 2nd MCP6002 from Task 2.

Using the waveform generator of the scope, measure the gain of this filter for the frequency range of 10Hz to 100kHz. Plot the amplitude response of this filter (in dB) vs log frequency. Explain the results. (You should use the “measure” feature of the scope to make this task easier.)

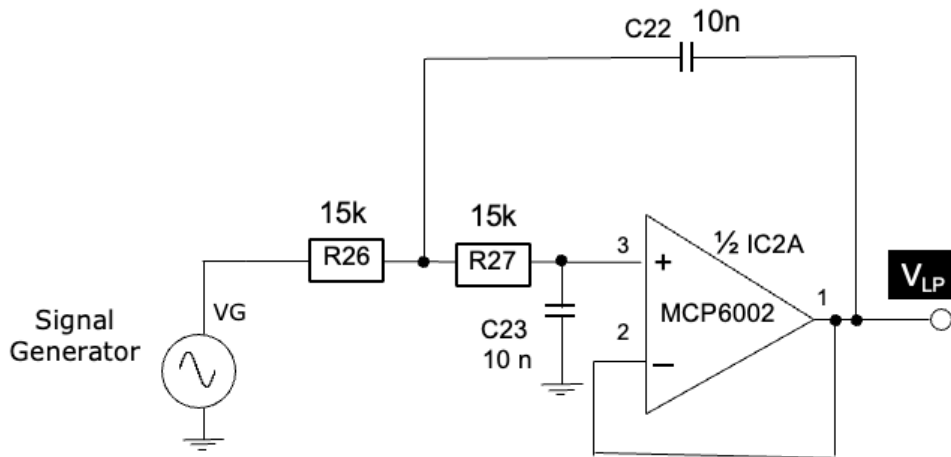

Connect the triangular signal from Task 3 to the input of this filter. You should now have a function generator that produces three types of waveforms: triangular, square and sine.

(Optional - If you have time, you might explore building and testing a highpass filter with a break frequency of 1kHz.)

Task 5: Analogue Pulse-width Modulator Circuit

Use the second op-amp in the 2nd MCP6002 and construct a simple comparator as shown below. Connect the triangular signal from Task 3 (with RV1 removed) to the negative input of the comparator. Use the RV1 as a variable DC threshold to the positive input of the comparator. You should observe a pulse-width modulated signal at the output of the comparator. State the relationship between the pulse width and the threshold voltage V_{th} .

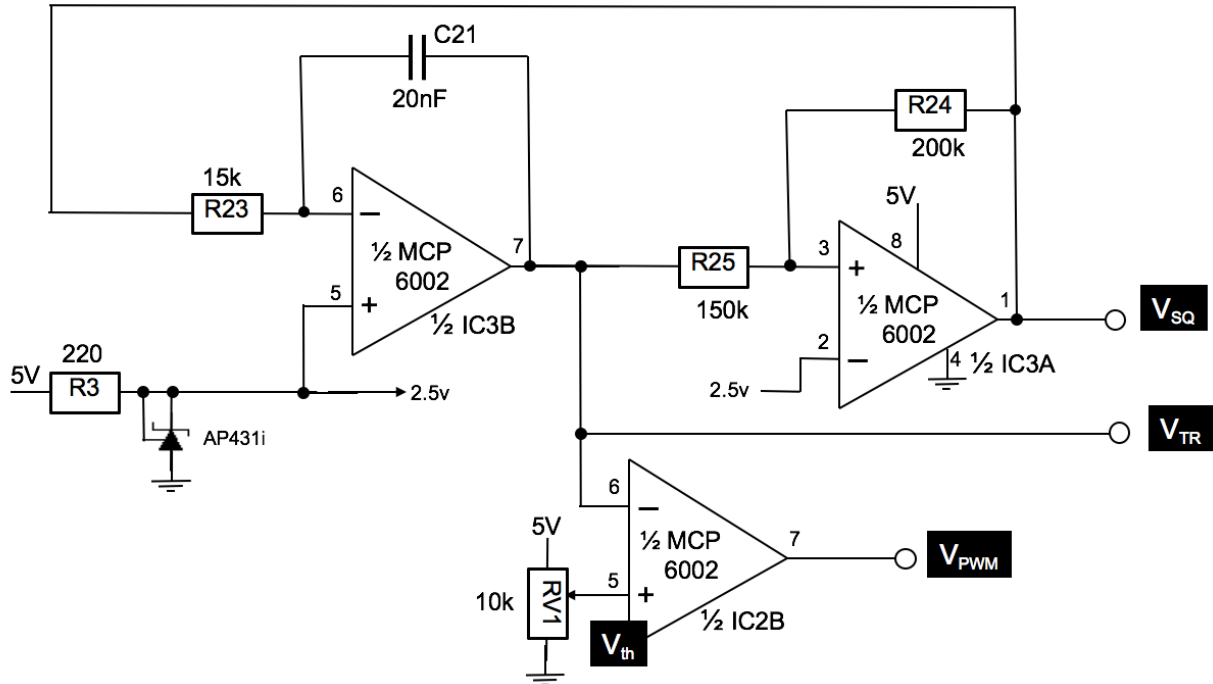

What is the relationship between V_{th} and average voltage (i.e. the DC voltage) of V_{PWM} ?

The lowpass filter from Task 4 perform an averaging function.

Connect V_{PWM} to the input of the lowpass filter from Task 4. Explain the results. Now change R23 from 15k to 1.5k and explain why there is a difference to V_{LP} .