

Lecture 7

Clocking Strategies in VLSI Systems

Peter Cheung
Department of Electrical & Electronic Engineering
Imperial College London

Reading: Weste Chapter 5; Rabaey Chapter 6

URL: www.ee.ic.ac.uk/pcheung/
E-mail: p.cheung@ic.ac.uk

Clock - key to synchronous systems

- ◆ Clocks help the design of FSM where outputs depend on both input and previous states.
- ◆ Clock signals provide reference points in time - define what is previous state, current state and next state:

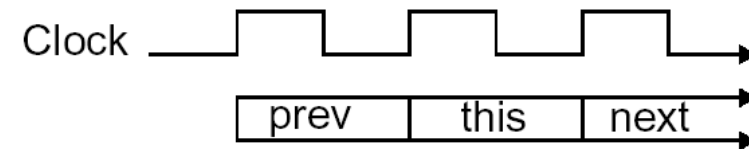

Latch vs Flip-Flop

● Latch

stores data when
clock is low

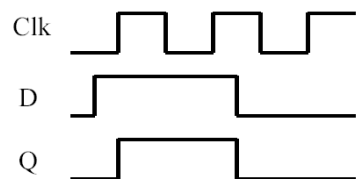
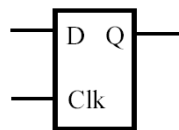

● Flip-Flop

stores data when
clock rises

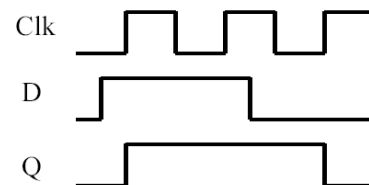
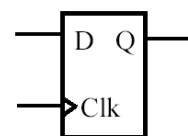

Clock for timing synchronization

- ◆ Clocks serve to slow down signals that are too fast
 - Flip-flops / latches act as barriers
 - With a latch, a signal can't propagate through until the clock is high
 - With a Flip-flop, the signal only propagates through on the rising edge
 - All real flip-flops consist of two latch like elements (master and slave latch)

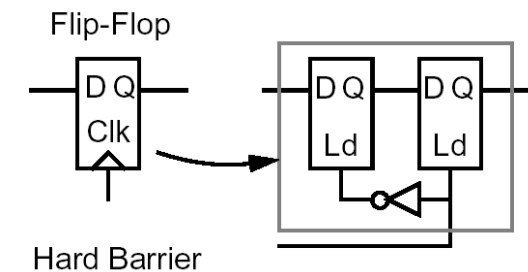
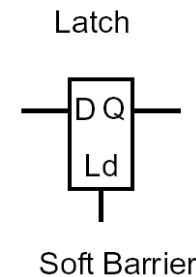

Latch Timing Parameters

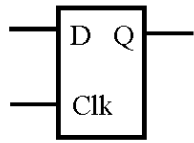

Unger and Tan
Trans. on Comp.
10/86

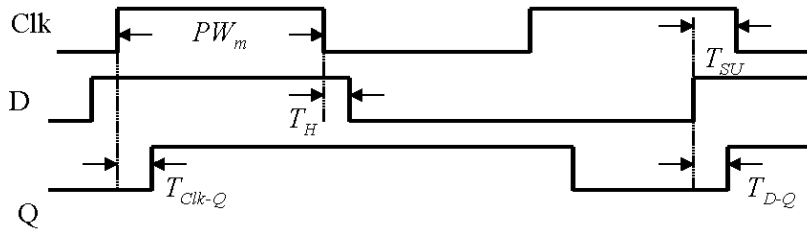

1-Feb-02

E4.20 Digital IC Design

Lecture 7 - 5

Flip-flop Timing Parameters

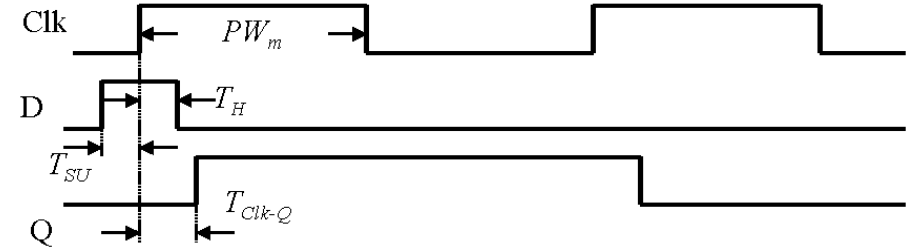
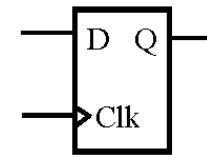

1-Feb-02

E4.20 Digital IC Design

Lecture 7 - 6

Typical Clock System

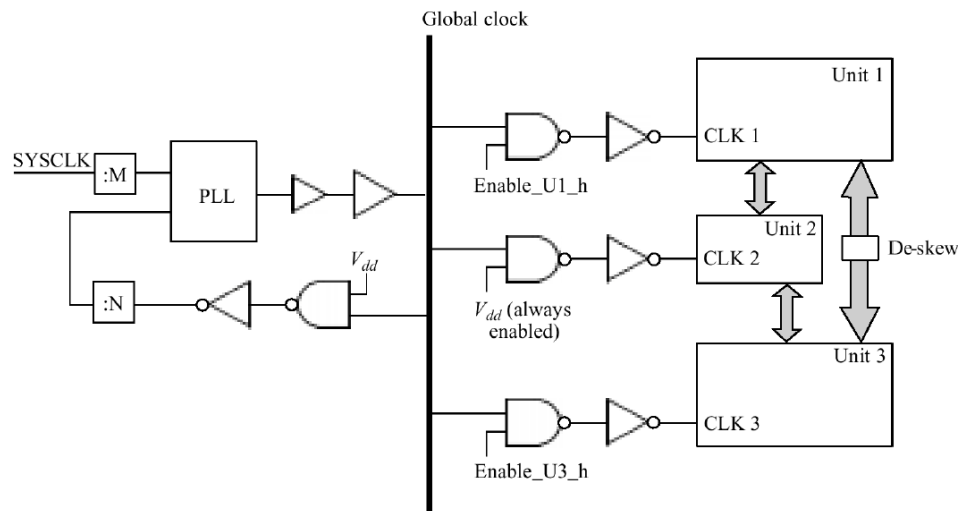

1-Feb-02

E4.20 Digital IC Design

Lecture 7 - 7

Clocking Overhead

- ◆ Latches and flops slow down the slow signals
- ◆ Flip-flop delays the slowest signal by the **setup + clk-q** delay
- ◆ Latches delay the late arriving signals by the delay through the latch

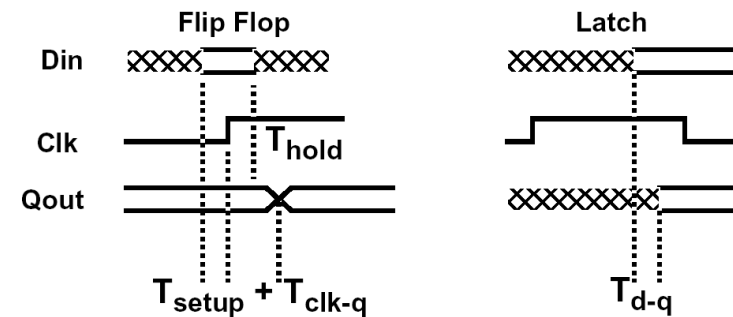

1-Feb-02

E4.20 Digital IC Design

Lecture 7 - 8

Problem of Clock Skew

Not all clocks arrive at the same time

- Some clocks might be gated (ANDed with a control signal) or buffered
- There is an RC delay associated with clock wire

Causes two problems

- The cycle time gets longer by the skew

$$T_{\text{cycle}} = T_d + T_{\text{setup}} + T_{\text{clk-q}} + T_{\text{skew}}$$

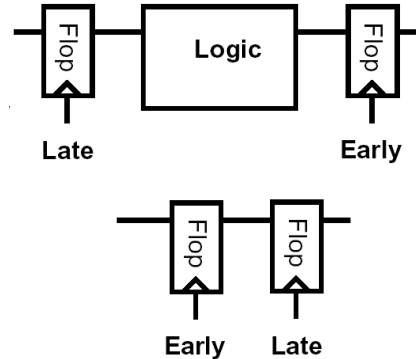

- The part can get the wrong answer

$$T_{\text{skew}} > T_{\text{clk-q}} - T_{\text{hold}}$$

Clock Skew and Jitter

◆ Clock skew

- Spatial variation in temporally equivalent clock edges; deterministic + random, t_{SK}

◆ Clock jitter

- Temporal variations in consecutive edges of the clock signal; modulation + random noise - Cycle-to-cycle (short-term) t_{JS} Long term t_{JL}

- Both skew and jitter affect the effective cycle time

- Only skew affects the race margin

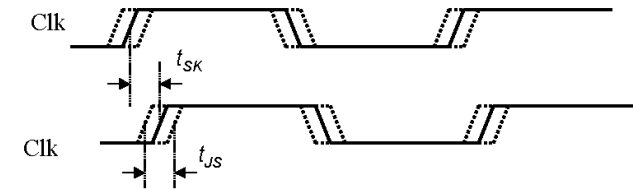

Longest Logic Path - Edge Triggerred

- Unger and Tran, Trans. On Comp. 10/86

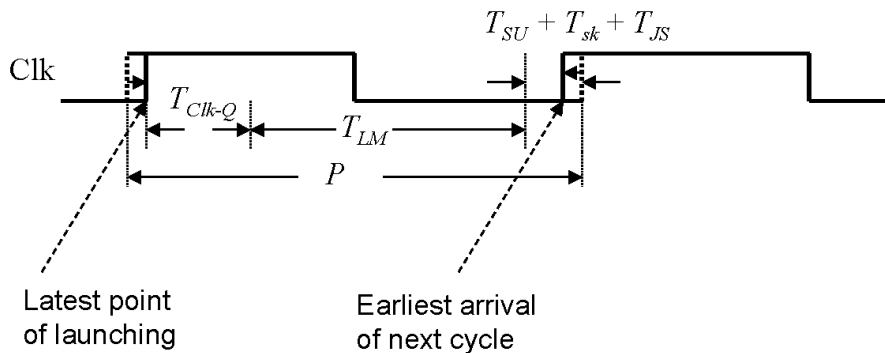

$$P \geq T_{\text{clk-QM}} + T_{LM} + T_{SU} + T_{sk} + T_{JS}$$

Shortest Path Constraint

- If launching edge is early and receiving edge is late:

$$-T_{\text{clk-Qm}} + T_{Lm} \geq T_{sk} + T_H$$

$$T_{Lm} \geq T_{sk} + T_H - T_{\text{clk-Qm}}$$

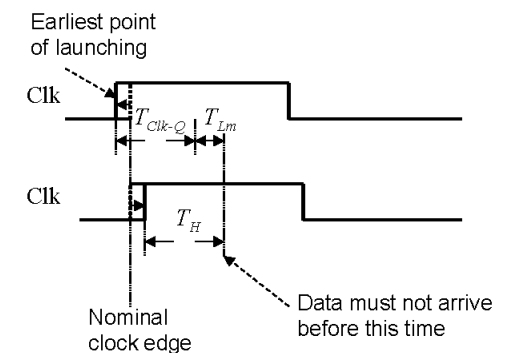

Clocking Strategies

- ◆ Trade off between overhead / robustness / complexity
- ◆ Constraints on the logic vs. Constraints on the clocks
- ◆ Look at a number of different clocking methods:
 - Pulse mode clocking
 - Edge triggered clocking
 - Two phase clocking
 - Single phase clocking
- ◆ We will only look at system level strategy - consider clocked circuits in the next lecture

Pulse Mode Clocking

- ◆ Two requirements:
 - All loops of logic are broken by a single latch
 - The clock is a narrow pulse
- ◆ It must be shorter than the shortest path through the logic

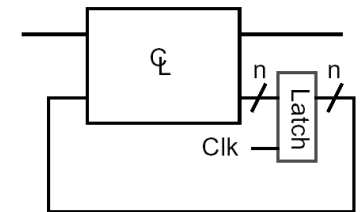
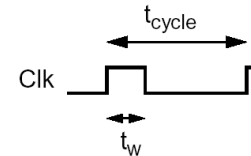

- ◆ Timing Requirements

$$t_{d\text{max}} < t_{\text{cycle}} - t_{d-q} - t_{\text{skew}}$$

$$t_{d\text{min}} > t_w - t_{d-q} + t_{\text{skew}}$$

+Pulse Mode Clocking

- ◆ Used in the original Cray computers (ECL machines)
- ◆ Advantage is it has a very small clocking overhead
 - One latch delay added to cycle
- ◆ Leads to double sided timing constraints
 - If logic is too slow OR too fast, the system will fail
- ◆ Pulse width is critical
 - Hard to maintain narrow pulses through inverter chains
- ◆ People are starting to use this type of clocking for MOS circuits
 - Pulse generation is done in each latch.
 - Clock distributed is 50% duty cycle
 - CAD tools check min delay
- ◆ Not a good clocking strategy for a beginning designer

Edge Trigger Flip-flop

- ◆ Popular TTL design style
- ◆ Used in many ASIC designs (Gate Arrays and Std Cells)
- ◆ Using a single clock, but replaces latches with flip-flops

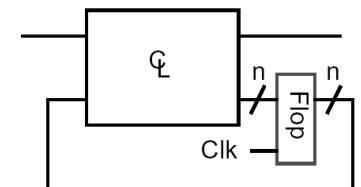
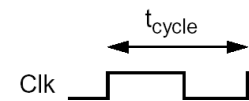

- ◆ Timing Constraints

$$t_{d\text{max}} < t_{\text{cycle}} - t_{\text{setup}} - t_{\text{clk-q}} - t_{\text{skew}}$$

$$t_{d\text{min}} > t_{\text{skew}} + t_{\text{hold}} - t_{\text{clk-q}}$$

- ◆ If skew is large enough, still have two sided timing constraints

Two phase clocking

- Use different edges for latching the data and changing the output

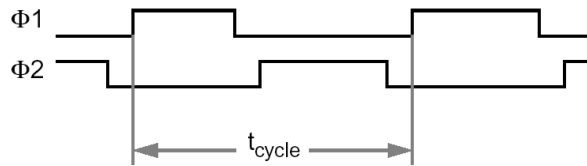

- There are 4 different time periods, all under user control:
 - Φ1 high
 - Φ1 falling to Φ2 rising
 - Φ2 high
 - Φ2 falling to Φ1 rising

Two phase clocking

- Look at shift register again:
 - If there is a large skew on the Φ2x clock, then the spacing between Φ1 and Φ2
 - can be increased to make sure that even with the skew, the Φ2 latch closes before the Φ1 latch lets the new data pass.
 - For some setting of the timing of the clock edges, the circuit will work!

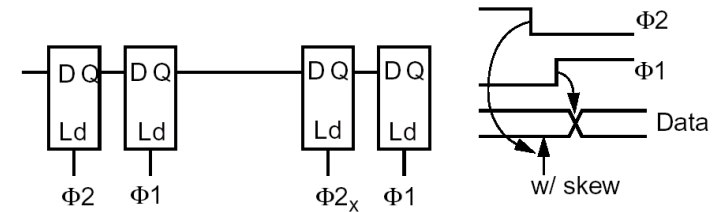

Stable signal type

- We will give signals timing types, so it will be easier to know which latch to use:
 - Output of a Φ1 latch is stable Φ2 ($_s2$) – good input to Φ2 latch
 - Output of a Φ2 latch is stable Φ1 ($_s1$) – good input to Φ1 latch
- Signal is called stable2, since it is stable for the entire Φ2 period

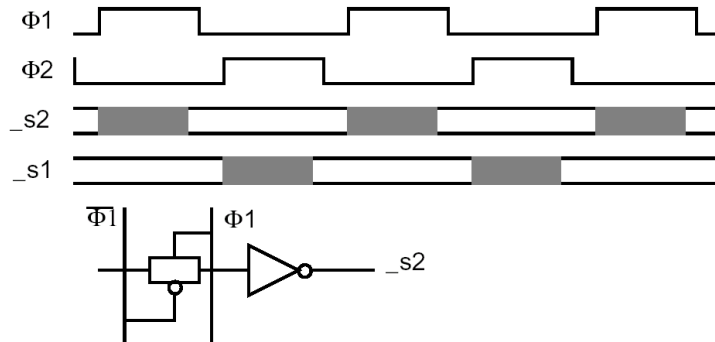

General two phase system

- Combination logic does not change the value of timing types.
 - No static feedback in the combination logic is allowed either. This makes the system not sensitive to logic glitches.

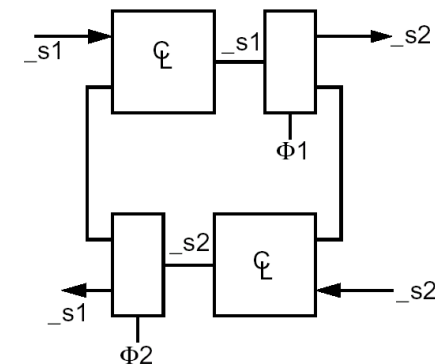

Why two phase clocking?

- ◆ It is a constrained clocking style:

- Synchronous design
- Two clocks
- Constrained composition rules

- But gives this guarantee:

- ◆ If you clock it slow enough (with enough non-overlap between edges)

- It will be a level sensitive design
- no race, glitch, or hazard problems
- no skew problems
- One sided timing constraints
- Impossible for logic to be too fast

Mealey and Moore Machines

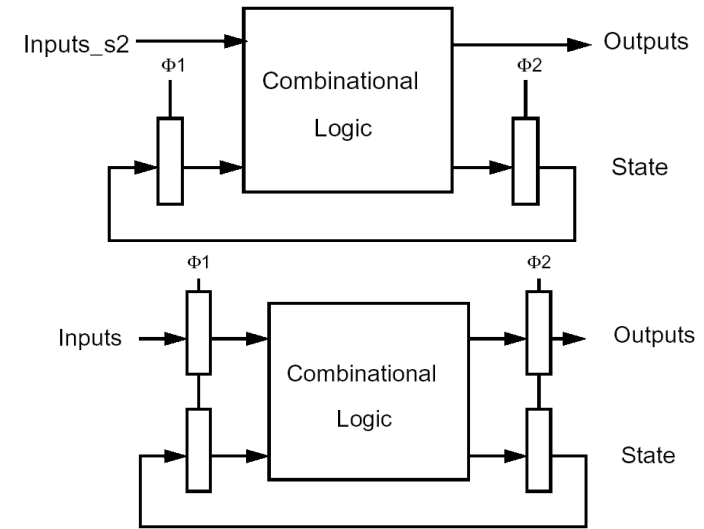

More on latch timing

- ◆ Look a little more closely at latches, to come up with a more complete set of timing types (more than $_s1$ $_s2$ signals) that we can use in our synchronous designs.

- Look at a latch since this the critical element

- ◆ What is the weakest requirement on the input to a latch?

- ◆ Signal must settle before $\Phi1$ falls, and not change for some time after $\Phi1$ falling, even for a skewed $\Phi1$ (this is usually called the setup and hold times of the latch)

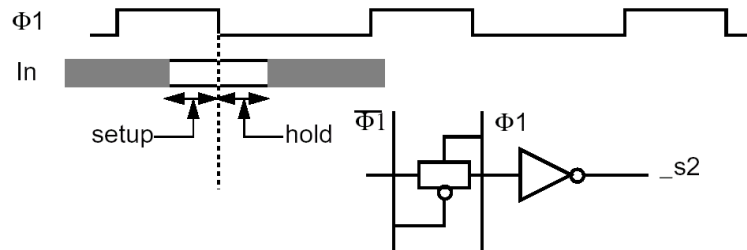

Valid Signal Type

- ◆ The weakest input to a latch is called a valid signal ($_v1$ $_v2$)

- For a valid signal we need to be sure we can guarantee it meets the setup and hold requirements of the latch

- ◆ To do this we need to have the signal settle off an edge that comes before $\Phi1$ falling. The closest edge is $\Phi1$ rising.

- ◆ The signal should not change until an edge occurs that comes after $\Phi1$ falling. The closest edge is $\Phi2$ rising.

- ◆ If we changed the input on $\Phi1$ falling, most of the time the circuit would work fine. But if it failed, we can't change the clock timing to make the circuit work -- $\Phi1$ falling controls the changing of the input, and the closing of the latch. Since we can't guarantee it would be ok a signal that changes on $\Phi1$ falling would not be a $_v1$ signal.

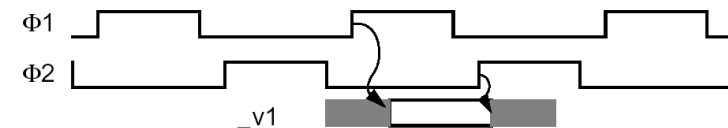

Use of valid signal

- ◆ Very useful for precharged logic
- ◆ Is not needed for standard combinational logic with latches
 - This should always give stable signals
- ◆ Can't use stable signals if you want to drive two signals/cycle on a wire (multiplex the wire), since the value has to change twice. There are many wrong ways to do it, and only one right way, which is shown below. The values become `_v` signals.

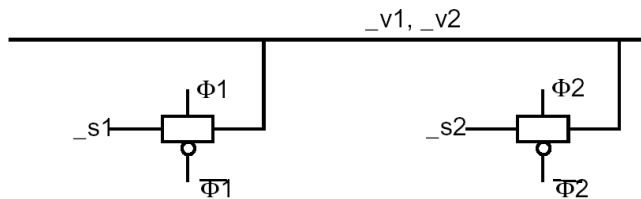

Stable Signals

- ◆ Have even larger timing margins than valid signals
- ◆ A `_s1` signal starts to change sometime after $\Phi 2$ rises
- ◆ A `_s1` signal settles sometime after $\Phi 2$ rises
- ◆ Input to the latch must be a `_v2` (settles after $\Phi 2$ rises)
- ◆ Output of a latch settles some small delay after input settles
 - Please note that combinational logic does not change the value of the timing type, even though it does increase the delay of the signal path. The timing types have to do with the clocking guarantee that we are trying to keep. This promise is that the circuit will work at some frequency. A `_s1` signal might not settle until after $\Phi 1$ rises when the part is run at high-frequency, but the label means that you can make that signal stabilize before $\Phi 1$ rises if you need to by slowing the clock down.

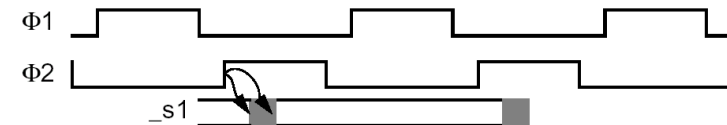

Qualified (Gated) Clocks

- ◆ These are signals that have the same timing as clocks, but they don't occur every cycle. They are formed by ANDing a '`_s1`' signal with $\Phi 1$ giving `_q1`, or ANDing a '`_s2`' signal with $\Phi 2$ giving a `_q2` signal.
- ◆ The control signal needs to be a stable signal to prevent glitches on the qualified clocks.
- ◆ Qualified clocks can only be used as the clock input to a latch

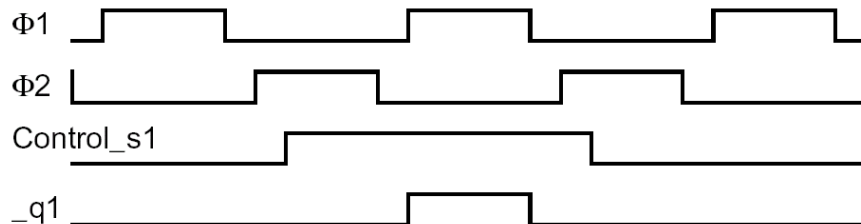

Summary of Clock Types

- ◆ The figure shows the timing of all the signals we have discussed with little arrows that indicate with clock edge caused the signal to change. Remember the pictures, and the timing types are what the signals look like at slow clock frequencies

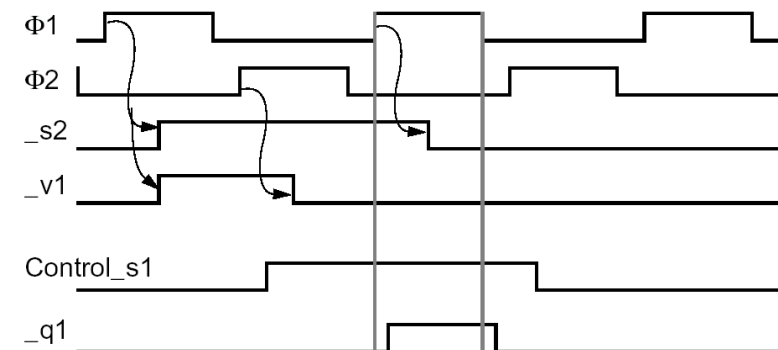

Disadvantages of two phase clocking

- ◆ Need four clocks in general
 - Need true and complement of both clocks
- ◆ Still need low skew for good performance
 - The skew increases the cycle time of the machine
 - Need low skew between all the clocks for good performance
 - Want to have $\Phi 1$ and $\Phi 2$ close to coincident
- ◆ Many systems use clock and its complement instead of 2 phases
 - Needless to say they are very careful about clock skew
 - For these systems it is still useful to maintain 2 phase timing types, since it ensures you connect all logic to the right latches
 - Call $\text{Clk} - \Phi 1$ and $\text{Clk} - \Phi 2$, and go from there.
 - Note in this class we will use $\Phi 1$ and $\Phi 2$ for clocks)

Advantage of Latches Over Flip-Flops

- ◆ If you are going to use Clk and Clk_b and control skew, why not go back to flip-flops?
- ◆ Many people do:
 - Most designs in industry are based on flip-flops
 - Very easy to verify timing
 - Each path between flip-flops must be less than cycle time
 - Tools check for skew and hold time violations
 - Short paths are padded (buffers are added to slow down the signals)
 - Skew in flip-flop based systems affects the critical path
- ◆ Latch designs are more flexible than a flip-flop design
 - Gives the designer more rope
 - Need to CAD tools to make sure it works
 - Can borrow time to allow a path to be longer than clock period
 - Can tolerate clock skew -- skew does not directly add to cycle time

Single-phase Clocking

- ◆ Unger and Tan, Trans. On Comp Oct 86

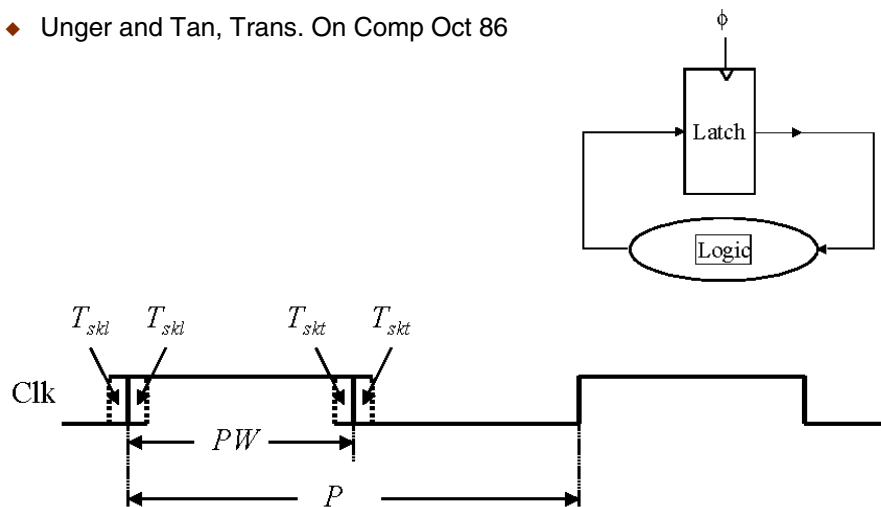

Latch-based Design with Single-phase clock

L1 latch is transparent when $\phi = 0$

L2 latch is transparent when $\phi = 1$

